



KP1000

Koolaire Ice Cube Machine

KDP1000A | KYP1000A | KDP1000W | KYP1000W

ICE SHAPES



▶ **Half-Dice:** 3/8" x 1 1/8" x 7/8"
(0.95 x 2.86 x 2.22 cm)



▶ **Dice:** 7/8" x 7/8" x 7/8"
(2.22 x 2.22 x 2.22 cm)

SIZE

- ▶ Up to 880 lbs (399 kgs) of daily ice production
- ▶ 30" (76.20 cm) wide, 34" (86.36 cm) deep, and 59.5" (151.13 cm) high including 6" (15.24 cm) legs
- ▶ 532 lb (241 kgs) ice bin storage capacity*

*Application capacity based on 90% volume x 33 lbs./ft³ average density of ice

Koolaire KP1000 Ice Cube Machine on K570 Bin.
Ice machine and bin sold separately.

SPECIFICATIONS

Refrigerant: R290

- ▶ Air-cooled: 14.1 oz (400 g)
- ▶ Water-cooled: 14.1 oz (400 g)

BTU Per Hour

- ▶ 14,080 (average)
- ▶ 16,340 (peak)

Operating Limits

- ▶ Ambient temperature range: 40° to 110°F (4.4° to 43.3°C)
- ▶ Water temperature range: 35° to 90°F (1.7 to 32.2°C)
- ▶ Water pressure ice maker (water in)
 - Min. 20 psi (137.9 kPa)
 - Max. 80 psi (551.1 kPa)
- ▶ Condenser inlet water in (water-cooled only)
 - Min. 20 psi (137.9 kPa)
 - Max. 275 psi (1,896.06 kPa)

Power

- ▶ 203-208/60/1 standard
- ▶ Minimum circuit ampacity:
 - Air-cooled: 8.6
 - Water-cooled: 7.9
- ▶ Maximum Fuse Size
 - Air Cooled: 15 Amps
 - Water cooled: 15 Amps

FEATURES / BENEFITS

- ▶ AHRI performance certified
- ▶ Energy-efficient model (see EnergyStar.gov)
- ▶ Durable nickel-plated copper evaporators (Made in Manitowoc, WI)
- ▶ Simple 3-position control: ON / OFF / CLEAN
- ▶ Smudge-resistant stainless-like exterior
- ▶ R290 offers a 99.86% GWP reduction compared to R410A
- ▶ Front-facing evaporator for easy access
- ▶ One-touch cleaning—just add chemical, no ice removal needed
- ▶ Tool-free removal of food zone components
- ▶ Smooth, white plastic interior for quick wipe-downs
- ▶ Sealed food zone with commercial-grade gaskets
- ▶ Alpha San antimicrobial protection in key parts

ACCESSORIES

- ▶ LuminIce® II Virus and Bacteria Inhibitor controls viruses and bacteria in the ice machine
- ▶ Dispenser Bin Thermostat Kit Reduces condensation when used with dispensers
- ▶ Arctic Pure® Pro Water Filters Reduces sediments and chlorine contaminants down to 0.5 microns Use with a pre-filter is recommended



LuminIce II



Thermostat Kit



Arctic Pure Water Filters

KP1000

Koolaire Ice Cube Machine

KDP1000A | KYP1000A | KDP1000W | KYP1000W

INSTALLATION

Ice machine must be installed indoors.

Required clearance for

- Top / Sides: 8" (20.3 cm)
- Back: 5" (12.7 cm)

- A** Electrical Entrance (2) Options
- B** 3/8" (0.95 cm) F.P.T. Ice Making Water Inlet
- C** 1/2" (1.27 cm) F.P.T. Ice Making Water Outlet
- D** 1/2" (1.27 cm) Condenser Water Outlet (water cooled units)
- E** 3/8" (0.95 cm) F.P.T. Condenser Water Inlet (water cooled units)
- F** 3/4" (1.91 cm) Bin Drain

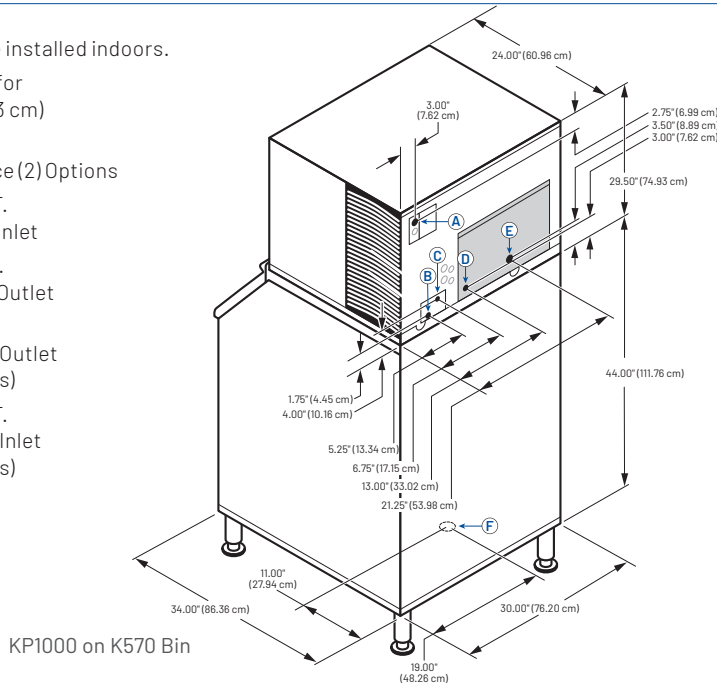

SPACE-SAVING DESIGN



**KP1000
K570**

Height	79.50" 202.93 cm
Width	30.0" 76.2 cm
Depth	34.0" 86.30 cm
Bin Storage	532 lbs 241 kgs

Height includes adjustable bin legs 6.00" to 8.00", (15.24 to 20.32 cm) set at 6.00" (15.24 cm).

Bin capacity is based on 90% of the volume x 33 lbs/ft³ average density of ice. Ice machine and bin sold separately.

SPECIFICATIONS

	Model	Ice Shape	Shipping Weight	Ice Production 24 Hours		Power Usage kWh per 100 lbs of ice	Ice Machine Potable water usage per 100 lbs ice @ 90° Air/70°F Water (32° Air/21°C Water)	Condenser water usage per 100 lbs ice
				70° Air/50°F Water 21° Air/10°C Water	90° Air/70°F Water 32° Air/21°C Water			
Air Cooled	KDP1000A	Dice	206 lbs (93 kgs)	846 lbs (383.7 kgs)	630 lbs (286 kgs)	4.7 ★	14 gal (53 L)	N/A
	KYP1000A	Half-Dice	206 lbs (93 kgs)	880 lbs (399.2 kgs)	688 lbs (312 kgs)	4.41 ★	14 gal (53 L)	N/A
Water Cooled	KDP1000W	Dice	203 lbs (92 kgs)	831 lbs (377 kgs)	719 lbs (326 kgs)	3.46	14.3 gal (54.1 L)	125 gal (473.2 L)
	KYP1000W	Half-Dice	203 lbs (92 kgs)	866 lbs (393 kgs)	740 lbs (336 kgs)	3.54	14.4 gal (54.5 L)	125 gal (473.2 L)

R290 is a refrigerant grade propane which is naturally occurring with no ozone depletion potential and extremely low global warming potential.

★ Energy Star Model

Limited Commercial Warranty

Ice Maker Three (3) years parts and labor

Evaporator Five (5) years parts and labor

Compressor Five (5) years parts, three (3) years labor



2110 South 26th Street | Manitowoc, WI 54220 | United States
+1.920.682.0161 | 920.683.7589 Fax | manitowocice.com

All indicated Pentair trademarks and logos are property of Pentair. Third party registered and unregistered trademarks and logos are the property of their respective owners. ©2025 Pentair. All rights reserved.